



**Wipro Furniture**  
**Education Range**

# Education Furniture

1 Lecture/Seminar Hall Seating

6 Hostel Furniture

10 Office Seating

2 Classroom furniture

7 Cabin Furniture

11 Lounge/Visitor Seating

3 Auditorium Seating

8 Office Furniture

12 Cafeteria Furniture

4 Library Furniture

9 Training Seating

5 Storage spaces

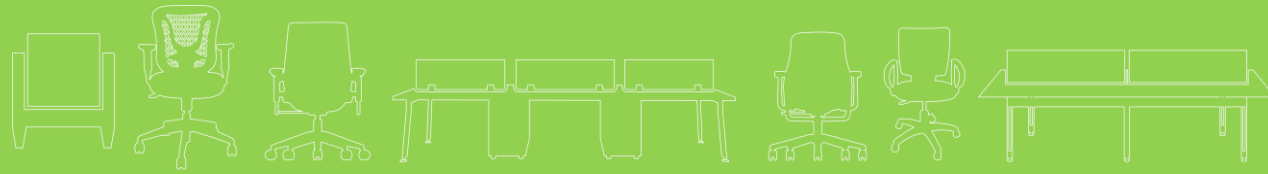

# Lecture/ Seminar Hall

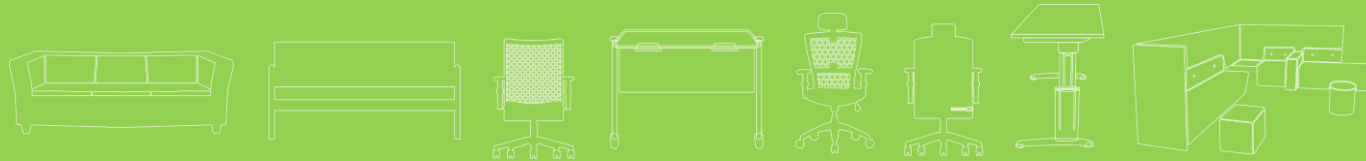



TEAMÜP



# TEAM UP



## Key Features

- Sleek and Sturdy Construction
- Suitable for both straight and curvilinear layouts
- In-built power & data provision makes “Team Up” ideal for “Smart classroom”
- Uniquely designed standardized & interchangeable table tops for quick installation.
- Elegant leg design is enhanced by ergonomically designed shoe caps

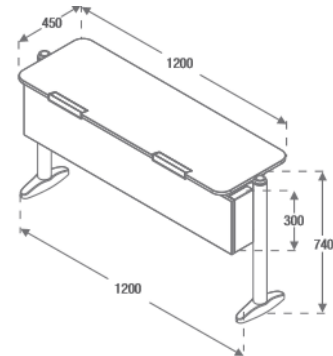

Available in two sizes : 1200 / 1350

# TEAM UP



# Admire

Stylish seating for Classrooms



# ADMIRE



## Key Features

- MDF Table top with die cast Aluminum legs
- Can be offered in step flooring or even flooring
- The seat has auto-tip up mechanism for smooth operations

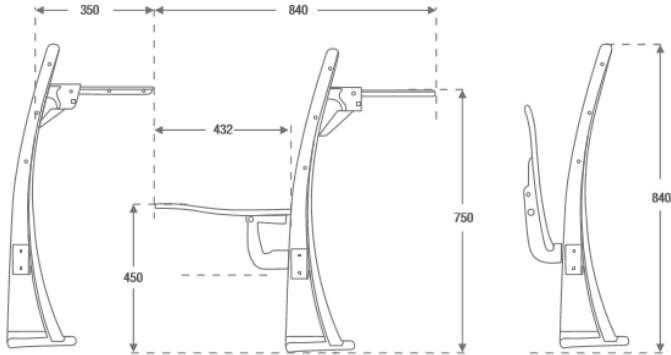



# ADMIRE



# Lecture/Seminar Hall Seating



PICC, Patna  
Product- Vibrant Plus



# Lecture/Seminar Hall Seating



PICC, Patna  
Product- Vibrant Plus

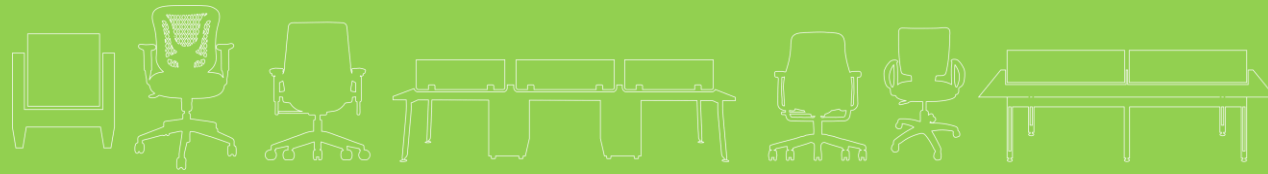

# Classroom Furniture

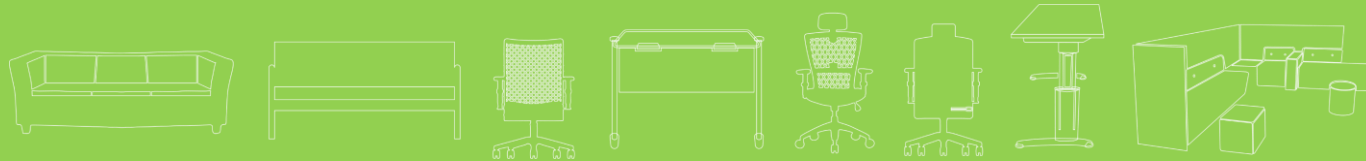

# Youngstar

Comfortable seating  
for all age groups

Senior  
K8 and  
above



Junior  
K4 - K7



Tiny Tots  
K1 - K3



# Youngstar



Junior  
K4 - K7

Desk

1S/2S - 500/900W x 400D x 610H

Chair - 420W x 370D x 630H | Seat - 340H



Tiny Tots  
K1 - K3

Table

1S/2S - 500/900W x 300D x 520H

Chair - 400W x 330D x 550H | Seat - 300H



Senior  
K8 and  
above

Desk

1S/2S - 600/1050W x 400D x 750H

Chair - 440W x 440D x 800H | Seat - 460H

- Independent desk and chair made of laminated ply with melamine coated edges - provides comfortable seating for all age groups.
- Comfortable seating for all age groups
- Comes with a provision for keeping books and bag hanging

# xplorer™

... for the smart ones



# Xplorer



## Key Features

- Sleek, Aesthetic and Flexible
- Better comfort level
- Designed to prevent tripping
- Ergonomic round edges for safe usage
- Easy to clean maintain and easy handling

Xplorer is an integrated table and seating system solution for classrooms and examination halls. It is sturdy, durable, colorful and streamlined.





# Xplorer





# Performer

International metal desk cum  
bench seating for classrooms

# Performer

An integrated two-seater desk cum bench that is ideally suited for modern classrooms. Performer is designed with high user safety in mind.



## Key Features

- Round top edges for safe use
- Angled table top for comfort when writing
- Structure is completely free from any sharp edges
- Sturdy and robust construction for durability
- Comes with a provision for keeping books and bag hanging

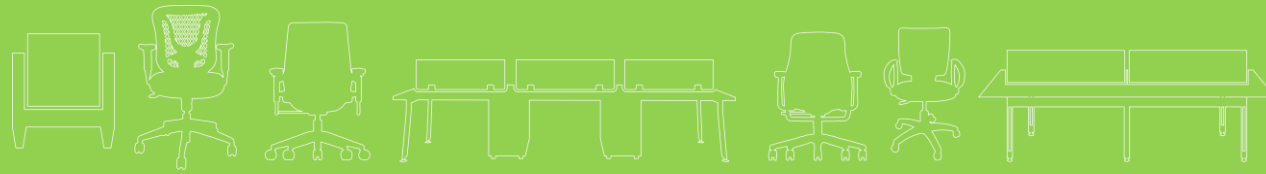

# Auditorium Seating

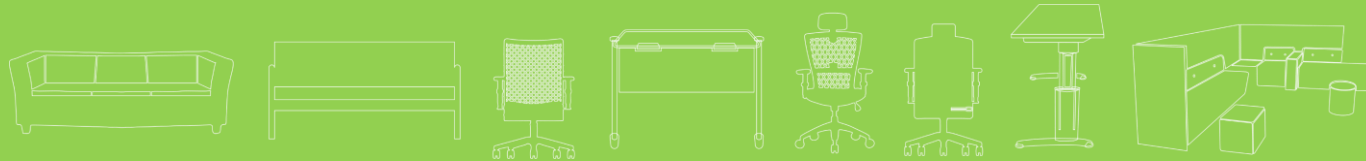

**BOX**<sup>TM</sup>  
**OFFICE**  
*nothing but performance!*



*Ballet*

*Push back | Auto tip-up*



*Symphony*

*Push back | Auto tip-up*



*Concert*

*Fixed back | Auto tip-up*

# Concert:

## Key Features:

- Specially designed large seats for relaxed seating
- Sleek and profiled 'V' wing – on Aisle side
- Polypropylene back & seat pan for easy maintenance
- Available in
  - PU armrest
  - With cup holder
  - Wooden Armrest



# Ballet

## Key Features

- Compact seating with waterfall edge design
- Choice of Push back with auto tip-up or fixed back & seat
- Polypropylene back & seat pan for easy maintenance
- Aesthetic look with fully fabric covered “Y” wings
- Available in
  - PU armrest
  - With cup holder



# Symphony:

## Key Features:

- Fluimatic Slider mechanism for superlative comfort
- Specially designed large plush seats for relaxed seating
- Polypropylene back & seat pan for easy maintenance
- “U” wing pocket that houses accessories discreetly
- Available in
  - PU armrest
  - Wooden Armrest
  - Wooden armrest with Tablet
  - With cup holder





# Auditorium

Suresh Bhat Auditorium, Nagpur  
Product – Ballet, Quantity-1997



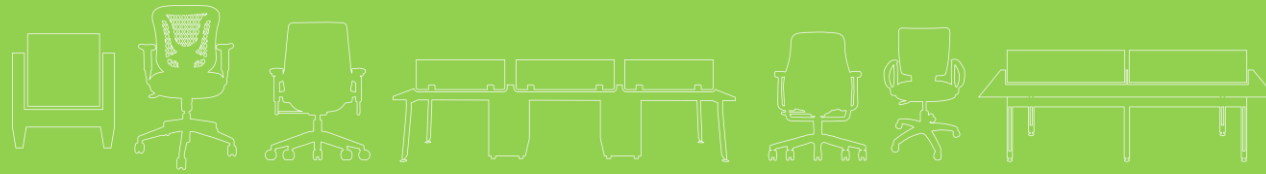

# Library Furniture

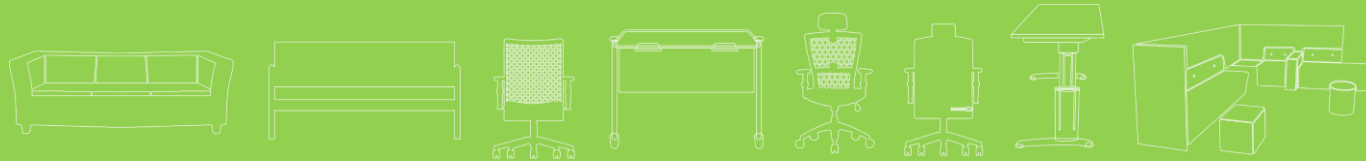

# search™

ease the whereabouts of knowledge



# Search

## Key Features

- The bottom three shelves of each unit are at a designed angle that enables quick locating of books/references
- Suitable for books of different heights, since lower 2 shelves are 280 mm height, suitable for larger size books.
- Available with 3 fixed bottom inclined shelves and 3 height adjustable top shelves to accommodate books of various size
- Available in single sided and double sided configurations with main and add on modules.
- Side, top and back panels are 18 mm BSL PLB Shelves are 25 mm thick BSL Prelam particle board Frames are made out of 2"x1" CRCA pipe.

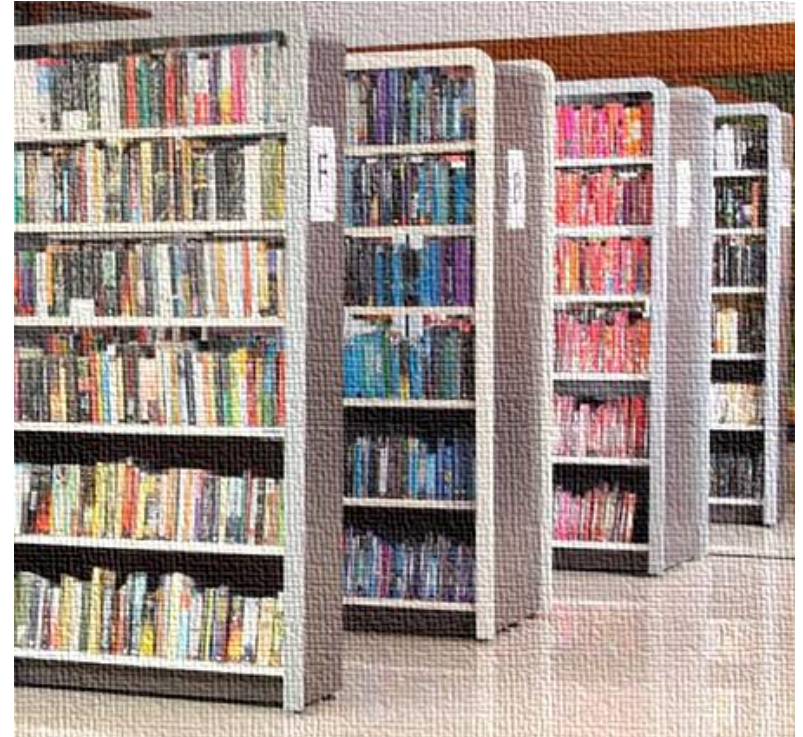

# Search



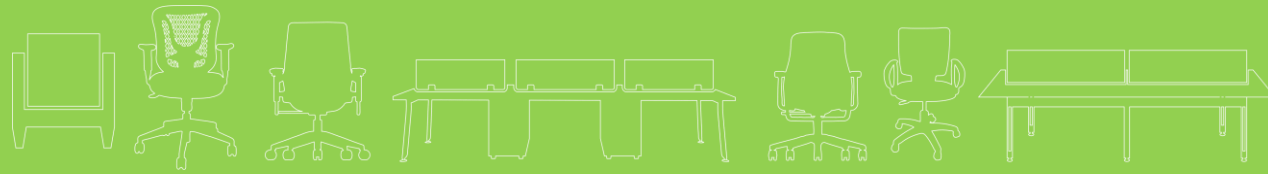

# Storage spaces

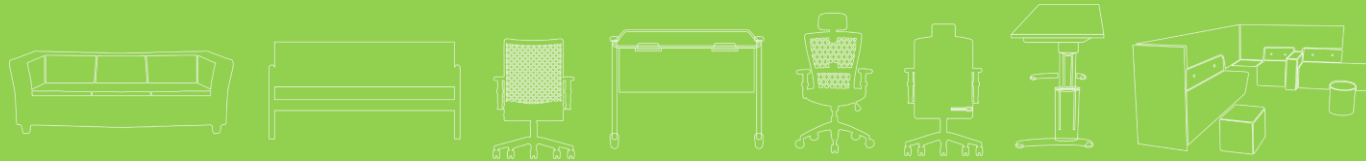

# WUDSAFE™

strong ■ safe ■ secure



# Wudsafe

WUDSAFE Pre-laminated finish storages



## Key Features:

- Range of Pre-laminated units
- Premium lock
- Wave key technology
- No sharp edges





# Wudsafe



# ENDURA<sup>+</sup>™

strong • safe • secure

# COMPACTOR



# Endura+

## Key Features

- Pulley Belt Drive Mechanism
- The Aluminum Tracks ensure an **easy & smoother movement** of the body over the rails.
- The installation of the compactors needs **no grouting**
- Platform available between the bays provides the user a **hindrance free walking** passage while accessing the compactor
- Uniquely designed handle with inbuilt lock facility
- Comes with the central and individual locking facility. Individual locking available on the rotating wheel
- Adjustable shelf for various shelf heights as per customer Req.



# Endura+



# Endura+

Cabinet



Lockers



Cupboards



Tambour door Unit



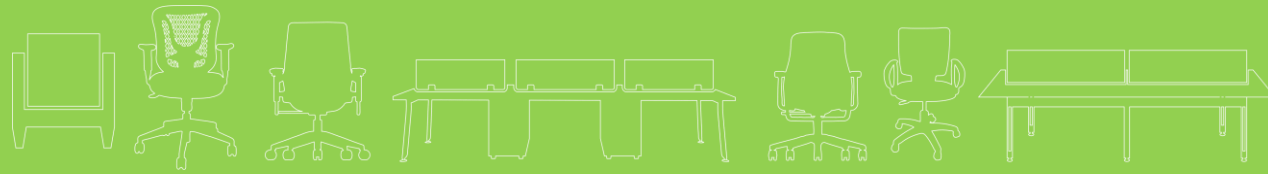

# Hostel furniture

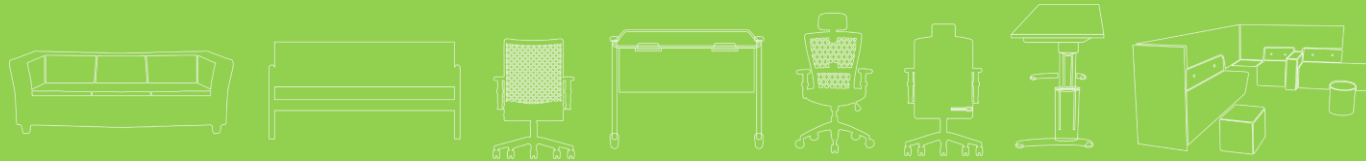

# HANGOUT™

Hostel furniture that make sense



# HangOut



A range of furniture that adds a definite character to the students' room.

Designed to last and withstand multi-handing by students, it gives a homely feel of warmth and comfort. Available in an array of furniture from study tables to hostel beds.

## Key Features

- Comprehensive range of hostel room furniture
- Ergonomically Designed for safe usage and effective utilization of hostel room space
- Creates ambience with flexibility, freedom and functionality



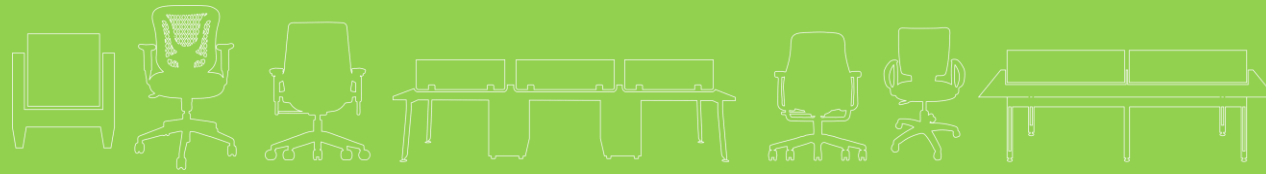

# Cabin furniture

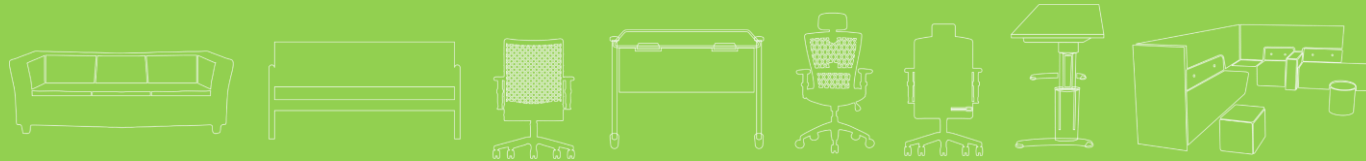



**EMBASSY™**  
— MAKE A STATEMENT —

# Embassy

## Key Features

- Embassy is available in variable sizes and configurations & is suitable for various work cultures.
- Embassy offers a complete cabin solution with offerings like – Main table, Side table, Main Table with integrated side storage, discussion Module, Rear Storage, Corner Table & pedestal.
- All the components of Embassy comes with membrane finish.



### Awards and Certifications



### Designed by



# CONSULATE



Designed by



I+D STUDIO



# Consulate

Consulate – a premium furniture system for people with vision who create their own distinctive signature.

## Key Features

- Contemporary Aesthetics and functionality
- Fine wood craftsmanship that refines design
- Concealed cable management keeps your work surface clutter free



- The table top and the gable end are made of layers of Pre-laminated particle panels pasted together to give the product strength and volume.



PRESIDENCY™



# Presidency

## Key Features

- A thoughtful and intelligent design with a trapezoidal table top for maximum space utilization
- All contact surfaces have Post-Lam finish on plain particle board and all structural components are pre-laminated Particle board
- Consulate offers a complete cabin set with offerings of - Main table, Main table with discussion module, Return Table, Rear modular storage & Pedestal





CHANCELLOR





# Chancellor



## Key Features

- Smart and sharp dual tone modesty and gable end
- Unique prismatic modesty panel provides elegant aesthetics
- Visibly thicker dual tone table top adds to the complete aura
- All table tops and understructure in pre-lam particle board

Awards and  
Certifications



Designed by



I+D STUDIO

# kingsley®



# Kingsley Platinum

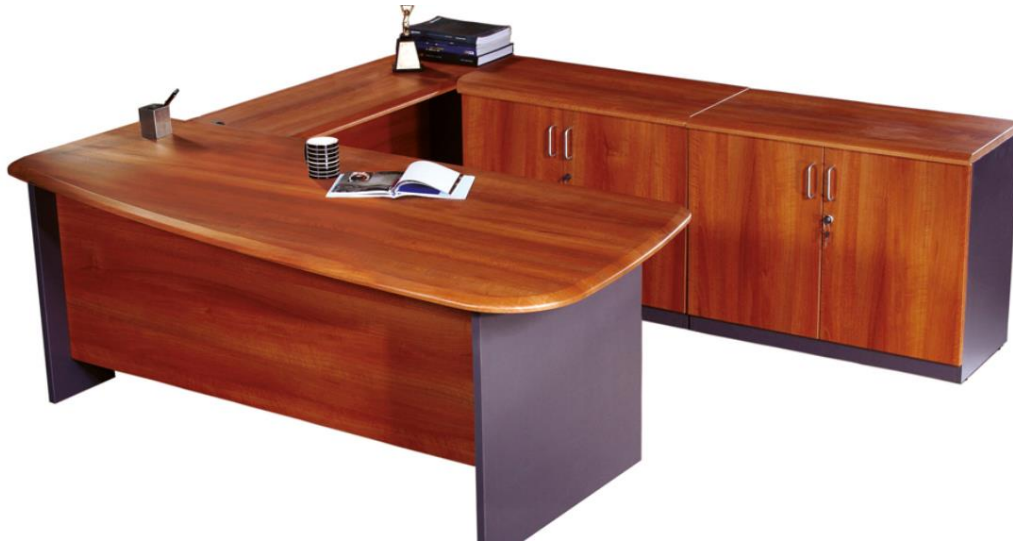

## Key Features

- Membrane finish special profiled table top with duck nose profile.
- Table top & Gable end is 25mm thick
- Modesty Panel is 18mm thick
- Kingsley `Platinum` offers a complete range with Main table, side table, rear storage , pedestals & discussion table

# Kingsley Supreme



## Key Features

- Table top is available in post-form finish.
- Gable end & Table top is 25mm thick ,  
modesty 18mm thick
- Available in Various sizes to cater different  
cabin requirement.

# Kingsley Premium



## Key Features

- 25mm thick pre-lam table top with D profile for increased seating depth
- Dual Tone understructure for Elegant look
- Side Return table with ideal ergonomic height of 700mm for laptop/keyboard usage

# Kingsley Discussion



## Key Features

- Kingsley is a world class range of furniture that lends stature and supremacy to office cabins.
- This discussion table is available in Membrane, Pre-laminated and Post form finish for various applications.
- Brings a Rich & Eloquent feel
- Superlative aesthetics

# Kingsley



# X Desk





# XDesk

Xdesk is a minimalistic open office architecture system ideally suited for light and trendy offices.



## **Key Features**

- Seamless integration of functionality and convenience
- Ideal for light and trendy open office
- Integrated wire management and clean understructure.

# XDesk



# Proceed



# Proceed

Proceed is an aesthetically pleasing and futuristically designed workstation that's suitable for youthful, open and collaborative environments.



## Key Features

- Sleek design that lends a unique and stylish look
- Integrated wire management with easy access
- Available as standalone or with side storages and pedestals
- Clean, clutter free looks

# Proceed



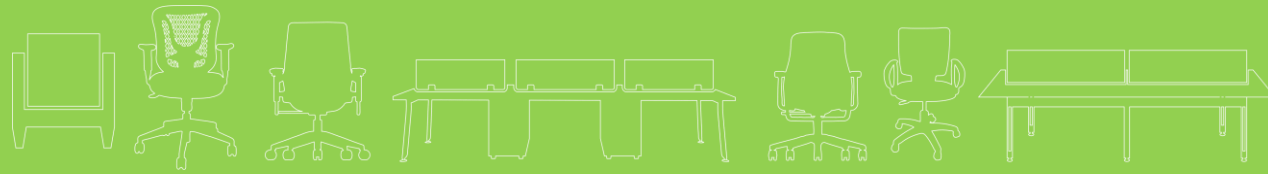

# Office Furniture

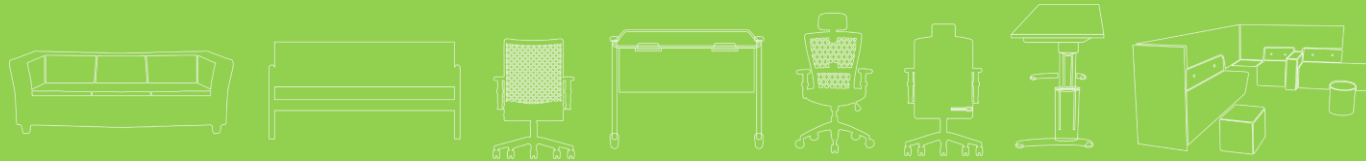

Seamless table tops, integrated wire management and clean under structures make X Bench ideally suited for light and trendy offices.

- ANSI/BIFMA X 5.5 Certified
- Pleasing aesthetics
- Choice of Fabric and Glass screens
- Seamless integration of functionality and convenience



Awards and Certifications



Proceed is an aesthetically pleasing and futuristically designed workstation that's suitable for youthful, open and collaborative environments.

- ANSI/BIFMA X 5.5 Certified
- Sleek design that lends a unique and stylish look
- Integrated wire management with easy access
- Available as standalone or with side storages and pedestals



#### Awards and Certifications





# VIBRANT<sup>®</sup>+

every space has a need

- Factory fitted tiles for easy and faster installation.
- Unique slide in tile features
- Various modules of frames, legs, work surfaces,
- storages, screens and accessories



# VIBRANT NXT

- Rugged and robust frame/tile based system
- Aluminum extrusion trims with glossy finish and powder coated
- Slant Designer legs with Translucent bushes
- Accessory rail integrated with Frame
- Hassel free and Faster installation at site
- Clutter free, complete bi-directional freedom of wire management
- A clean entry for cables from the floor, walls and ceiling into the partition
- Choice of power beam position – above/ below worktop



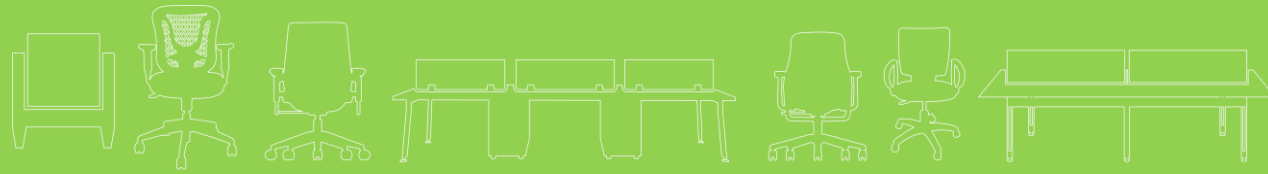

# Training Seating

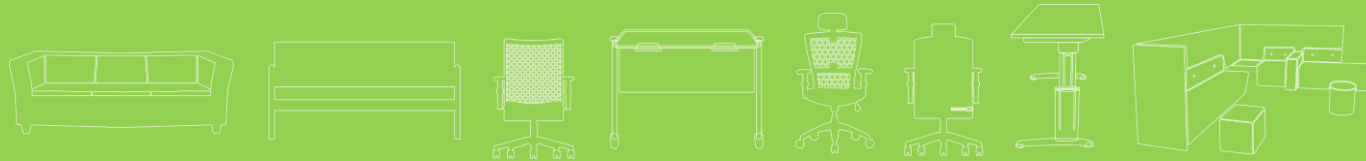

Pause is characterized by its sleek, contemporary looks combined with versatility and nestability. With standalone and beam configurations, this multifunctional chair is a perfect choice for seating in waiting lounges, training rooms and offices.

- Flexible seat made of high performance plastic
- Moulded contour back for seating comfort
- Sleek profiled arms integrated with slender and strong frame

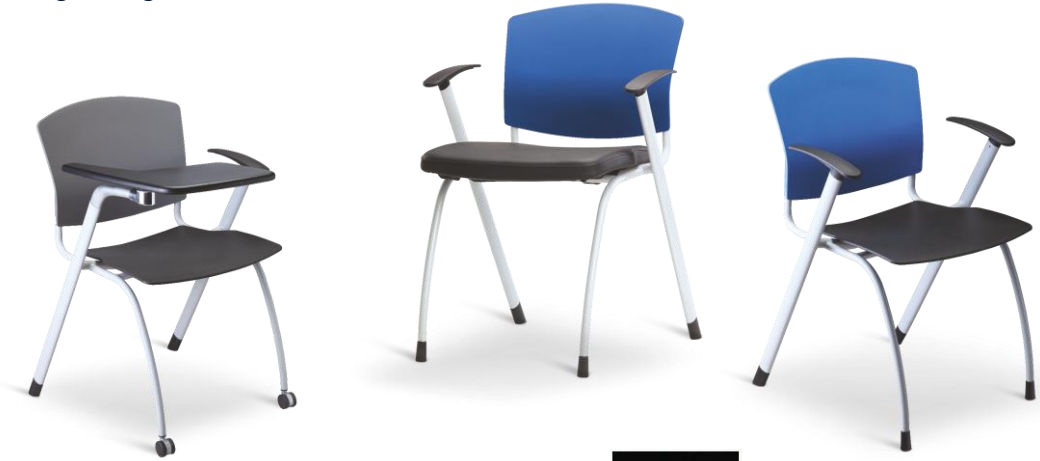

Awards and Certifications



by  
  
Conrad Marini, Toronto



# Pause



Transit symbolizes the joy of a product that's simple and easy to use with amazing utility and convenience. Light weight and easy to maintain, Transit is an effective way to create public spaces like food courts, cafeterias, waiting lounges, classroom, conference halls etc.

- Stackable and portable
- High performance polypropylene moulded seat and back
- Antiskid nylon pads



by   
Conrad Marini, Toronto



Awards and Certifications



# Transit



Annexe has earned the reputation of being India's most comfortable training cum visitor chair. Annexe effectively addresses the dual purpose required in a visitor and training chair.

- Easy stackability of both visitor as well as training chair
- Specially designed curvy under structure profile for enhanced strength and stability
- A well designed chair for long seating hours - a boon during training sessions





# PEP!

with you... everywhere

Pep is a general purpose chair that fits perfectly in trendy office environments. This compact and light chair is designed to be quickly moved around in the office, making it truly useful everywhere in the office.

- Versatile and compact
- Outstanding comfort and quality
- Built with premium materials and finish



# Wudmate

- It is stackable and light weight
- The contoured arms are completely joint less providing greater strength and stability.
- Waterfall edge design of the seat allows a knee position that does not constrict blood circulation, keeping you comfortable over long hours
- Green and Eco Friendly product
- Easy to assemble and disassemble- only 12 screws



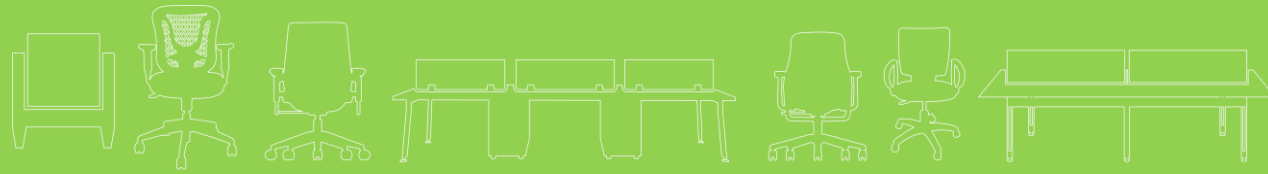

# Office Seating

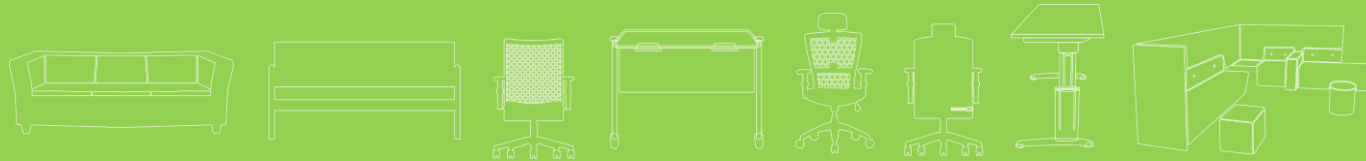

# Define

Define is made from selected leather and fabric that perfectly suits body temperature. Its premium finish makes Define a perfect chair for use by Top management and in Board rooms

- Contoured design
- Water fall seat edge
- Synchronised mechanism with intuitive control



# Smart

Smart is ergonomically designed with Indian Anthropometric dimensions in mind. Its lightweight frame gives it a unique multifunctionality in offices, cabins and meeting rooms.

- Ergonomically contoured backrest for better support in the lower back region
- High Resilience foam (H.R. Foam) waterfall edge seat which retains original shape and ensures proper blood circulation
- Versatile for use across the office

## Awards and Certifications



# Adapt

Adapt is a premium Chair with innovative technology and contemporary good looks. An automatic tension adjustment control adapts according to the user's weight ensuring the body is perfectly balanced and supported.

- Automatic weight sensing mechanism. Also available in Synchro 1 Mechanism
- Comes with Medium back and visitor options
- Two position locking for maximum comfort



## Awards and Certifications



# Sirius

Sirius is a beautifully designed chair which comes with a nicely contoured back profile making it truly refreshing.

- Comes with easy reclining mechanism which adjusts automatically to your weight without the need to set any controls
- Friction free back support with adjustable lumbar



Awards and Certifications



# Alivio

Alivio, a chair that radiates comfort combined with flamboyant looks, is ideally suited for use in executive cabins for top managers, corporate board rooms as well as task seating.

- S-contoured chair back for good lumbar support
- Retractable armrests that slide back, enabling good elbow support while working
- Synchro tilt mechanism for co-ordinated movement of the seat and back



Awards and Certifications





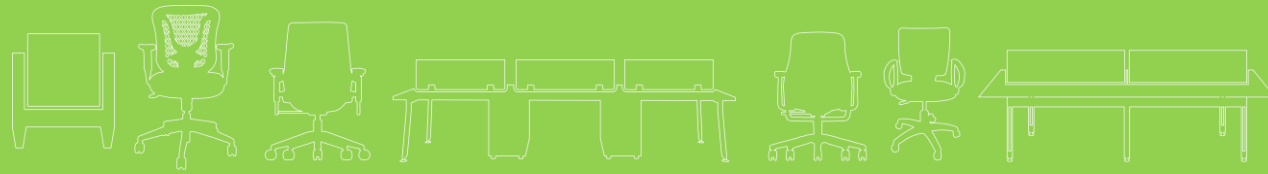

# Lounge/Visitor Seating

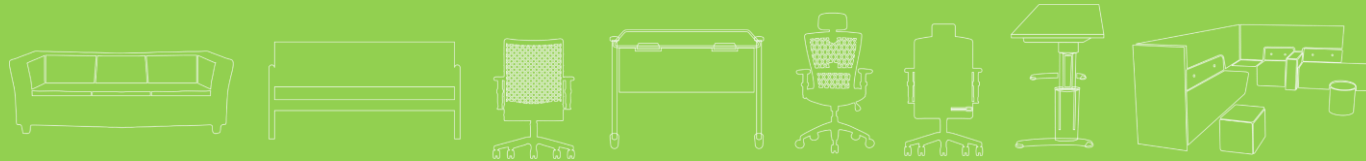

# Visitor Seating

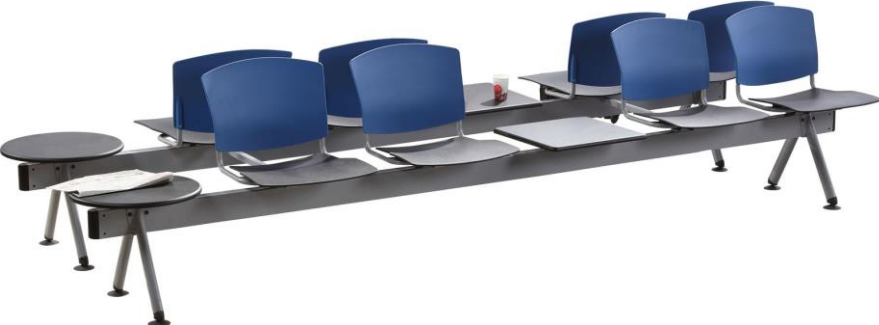

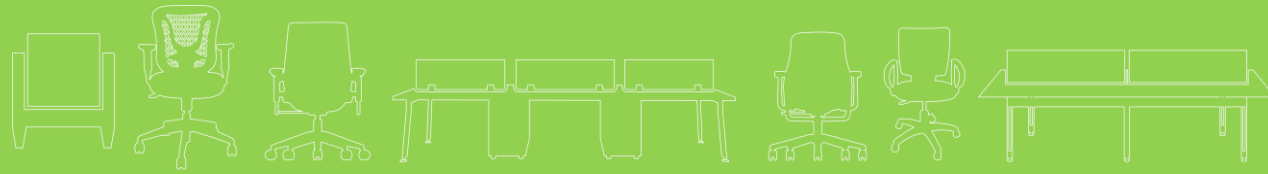

# Cafeteria furniture

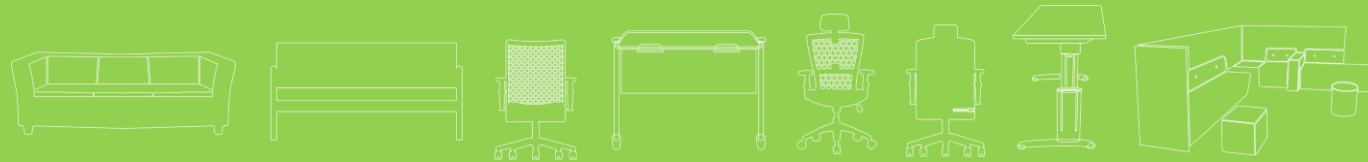







# Thank You

