



# COMPACTOR

EXPAND YOUR SPACE



**ENDURA**<sup>TM</sup>  
strong • safe • secure

# COMPACTOR

Endura+ Compactors allow you to maximise utilisation of your precious space. These compactors are built for durability using best quality materials and finishes. The salient features are:

- Self-supporting design which eliminates grouting and prevents floor damage
- Noiseless pulley-belt drive mechanism
- Aluminium rail for smooth operation and ease of handling



## 50% SPACE SAVING

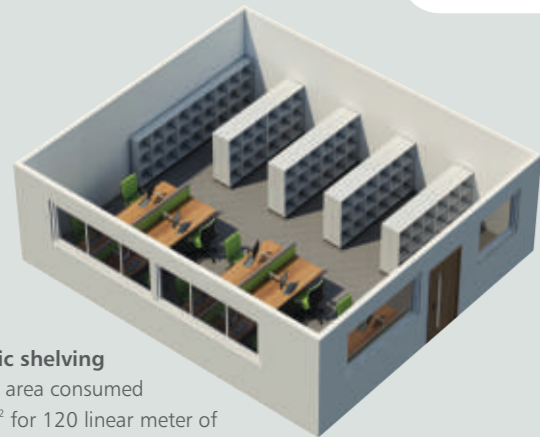

**Static shelving**  
Total area consumed  
18m<sup>2</sup> for 120 linear meter of  
storage space



**Compactor shelving**  
Total area consumed  
9m<sup>2</sup> for 120 linear meter of  
storage space

## FEATURES

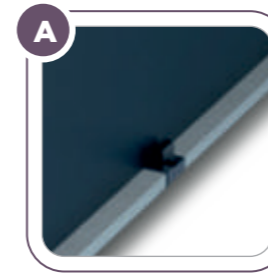

SELF-SUPPORTING  
INSTALLATION

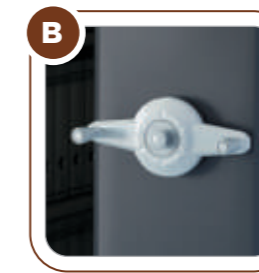

ERGONOMIC HANDLE with  
INTERNAL SAFETY LOCK



WOODEN PLATFORM with  
levelers and ERGONOMIC  
ACCESS RAMP



ADJUSTABLE SHELF with  
25mm pitch

## DIMENSIONS

1 Bay Deep + 4 Rows			
	H	W	D
Dimensions Overall	2100	1060	450/900
Dimensions Internal	1985	900	438/888
Track & Trolley Height	115		
Capacity Per Shelf: 10 Box files			

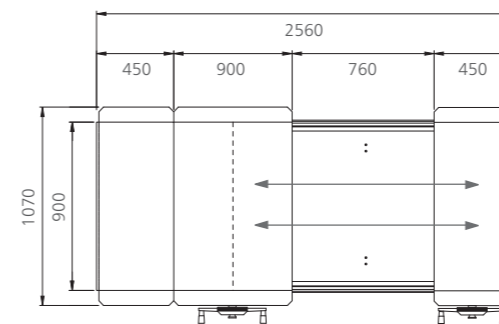

TOP VIEW

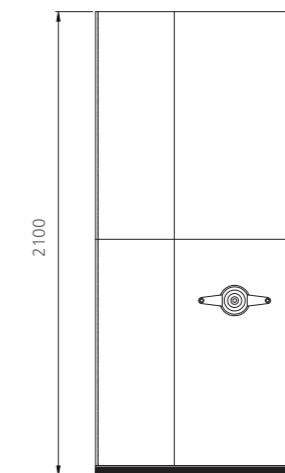

FRONT VIEW

**ENDURA+**  
strong • safe • secure

RANGE OF STEEL  
STORAGE SOLUTIONS



SWING DOOR  
CUPBOARDS



VERTICAL FILING  
CABINETS



LATERAL FILING  
CABINETS



LOCKERS



TAMBOUR DOOR  
CUPBOARDS



SLIDING DOOR  
CUPBOARDS



2-in-1 CUPBOARDS



BOOK CASE

# COMPACTOR

Endura+ Compactors allow you to maximise utilisation of your precious space. These compactors are built for durability using best quality materials and finishes. The salient features are:

- Self-supporting design which eliminates grouting and prevents floor damage
- Noiseless pulley-belt drive mechanism
- Aluminium rail for smooth operation and ease of handling



**50% SPACE SAVING**

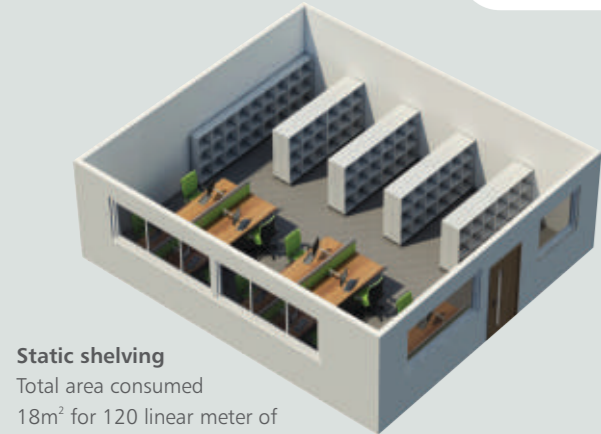

**Static shelving**  
Total area consumed  
18m<sup>2</sup> for 120 linear meter of storage space

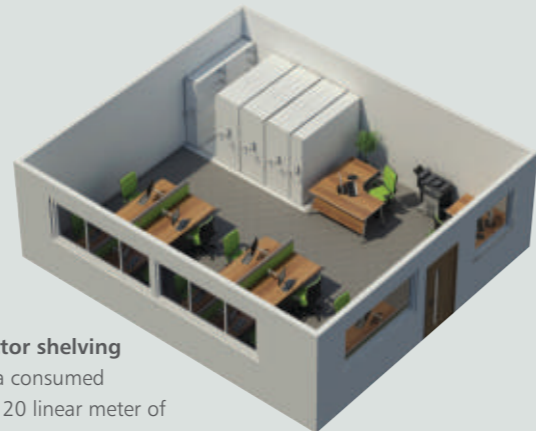

**Compactor shelving**  
Total area consumed  
9m<sup>2</sup> for 120 linear meter of storage space



## FEATURES

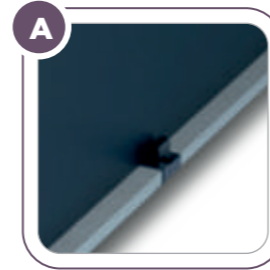

SELF-SUPPORTING INSTALLATION

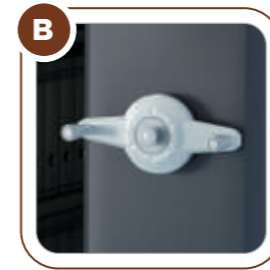

ERGONOMIC HANDLE with INTERNAL SAFETY LOCK



ALUMINIUM RAILS for SMOOTH OPERATION



WOODEN PLATFORM with levelers and ERGONOMIC ACCESS RAMP



ADJUSTABLE SHELF with 25mm pitch



CENTRAL LOCKING

## DIMENSIONS

1 Bay Deep + 4 Rows			
	H	W	D
Dimensions Overall	2100	1060	450/900
Dimensions Internal	1985	900	438/888
Track & Trolley Height	115		
Capacity Per Shelf: 10 Box files			

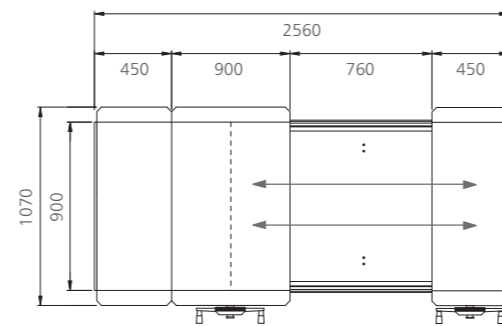

TOP VIEW

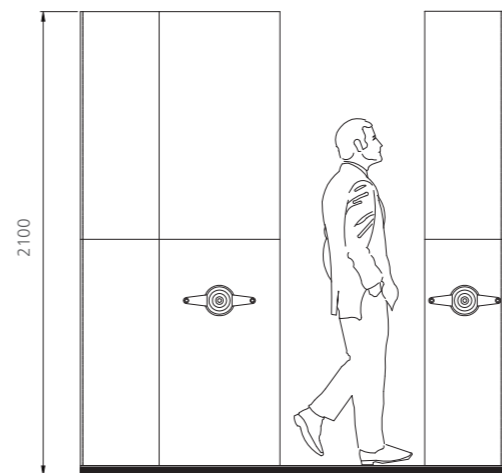

FRONT VIEW

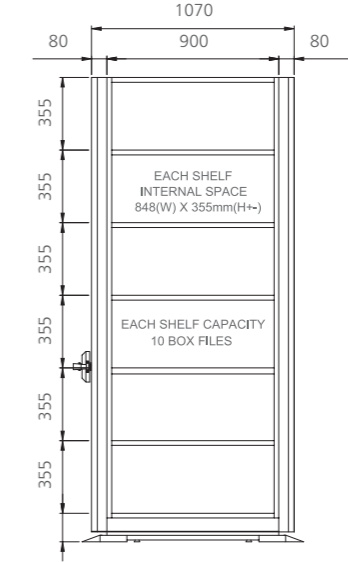

SIDE VIEW

All dimensions in mm

## CONFIGURATIONS & DIMENSIONS

### 1 Bay

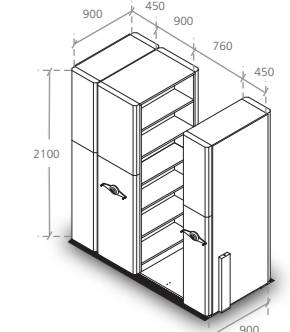

### 2 Bay

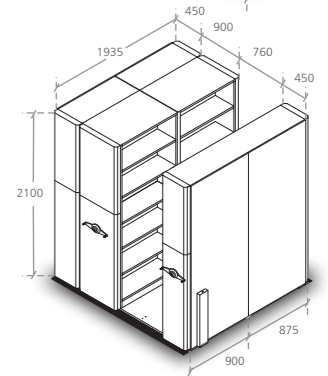

### 3 Bay

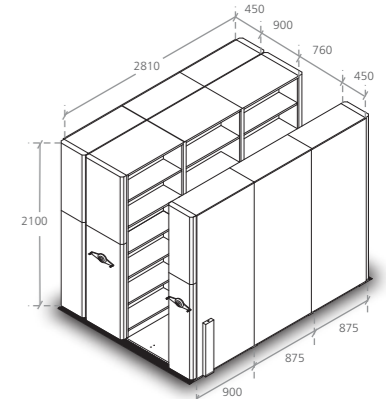

### 4 Bay

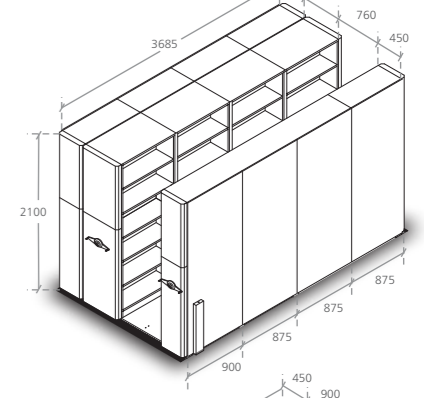

### 5 Bay

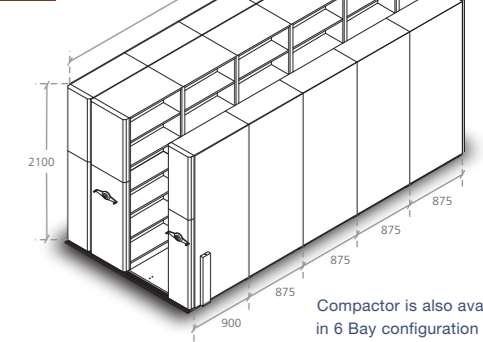



Compactor is also available in 6 Bay configuration



## TECHNICAL SPECIFICATIONS

DIMENSION BRIEF	Compactor Height from ground is 2100 mm (1985 body + 75 mm undercarriage + 40 mm channel system).
CONSTRUCTION	Complete construction of system is on knock down design for easy handling of material on site.
	Rigid upright frame made out of 1.2 mm thick CRCA steel box pipe .Upright with 25 mm x 50 mm rectangular slotted pipe.
SCALABILITY	Compactor is available in 1 Bay to 6 Bay configuration
	Bays can be added row wise or column wise subsequently, as per requirement.
POWDER COATING	All metal components are given anti-rust surface treatment & are powder coated with Epoxy Polyester Powder.
	It involves 8 tank treatment consisting of Degreasing, Water rinse, Phosphating & Dry off oven treatment.
	Final finish consists of Epoxy Polyester Powder coating with a dry film thickness of 60-80 microns.
	The testing of paint is done for various physical & chemical properties as per IS: 101.
NUMBER OF SHELVES	Each unit has 6 loading levels formed by 5 nos. adjustable shelves.
	438 mm depth is available for storage of box file as well any odd size folders.
SHELF THICKNESS	0.8 mm CRCA with stiffner. Shelves are mounted on support brackets & shelf level can be adjusted at 25 mm pitch.
LOAD CARRYING CAPACITY	80 kgs UDL (Uniformly Distributed Load).
UPRIGHT	Rigid construction made out of 1.2 thick CRCA steel upright with 25 mm x 50 mm rectangular pipe.
CLADDING	0.7 mm CRCA sheet metal panels.
OPTIONAL DOORS	Optional doors with lock on each bay can be provided.
TRACK MATERIAL	Aluminium track makes the movement smooth and the system rust proof against water contact.
PLATFORM FOR WALKWAY	25mm thick laminated particle board is provided for easy access from the walkway. Shade – Dark Grey (standard).
SLOPING RAMP	Sloping ramp in Aluminium (with natural finish) for easy trolley access & reduced tipping hazard.
LEVELERS	Easily adjustable levelers to keep platform & track parallel on uneven surfaces.
INSTALLATION OF TRACK	No Floor grouting is required for installation; making the installation drill free.
ASSEMBLY OF TRACK	Complete track assembly is on self supported design, suitable for any surface like cement, tiles, carpet etc
MECHANISM	Pulley-belt mechanism results in noiseless & oil free operation.
HANDLE	Ergonomic plastic handle with in-built safety lock mechanism.
LOCK	Central Locking on the last unit (locks entire assembly).

COLOR OPTIONS	Dual Tone	Mono Tone
	 Warm Grey - Graphite	 Warm Grey    Snow White



Wipro Enterprises Private Limited - **Furniture Business**

Doddakannelli, Sarjapur Road, Bangalore - 560035

Customer care number: 1800 425 1969

Write to us at [vibrant.solutions@wipro.com](mailto:vibrant.solutions@wipro.com)

Ahmedabad: +91 79 40073546, Bangalore: +91 80 40541237, Chandigarh: +91 172 2661355, Chennai: +91 9500088426  
 Cochin: +91 9387881504, Hyderabad: +91 40 27176082, Indore: +91 731 4023486, Kolkata: +91 33 22829268  
 Mumbai: +91 7406002777, Nagpur: +91 712 2233562, New Delhi: +91 11 41708122, Pune: +91 20 25535081  
 Vadodara: +91 8758856507