



# Steel Storage Solutions



Endura+ is a premium range of Steel Storage Solutions that reflects strong build quality and durability. With Endura+ you can be rest assured that your valuables are safe and secure. This range comes in Knocked-down condition making installation quick and convenient.



SWING DOOR CUPBOARDS

LOCKERS

TAMBOUR DOOR CUPBOARDS

SLIDING DOOR CUPBOARDS



VERTICAL FILING CABINETS

LATERAL FILING CABINETS

2-in-1 CUPBOARDS

PEDESTALS

## LATERAL FILING CABINETS

**Endura+** Lateral Filing cabinets are best suited for use in corporate offices, manufacturing units, PSUs, banks, etc.

- Centralised locking
- Anti-tilt mechanism to prevent toppling
- Heavy duty full extension ball bearing slides
- Load carrying capacity of 40kgs



No. of Drawer	Width	Depth	Height
2	900	450	715
3	900	450	1035
4	900	450	1335

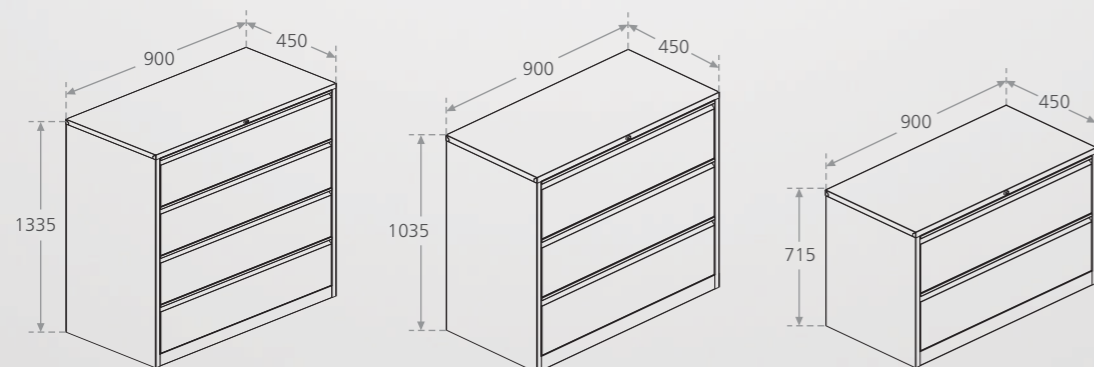
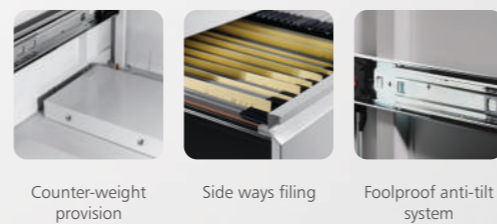

All dimensions in mm

## VERTICAL FILING CABINETS

**Endura+** vertical filing cabinets offer more linear meters of filing space per drawer and are designed to accommodate suspension files as well as box files. These filing cabinets are very sturdy by design as they come with unique fastener-free construction.

- Centralised locking
- Anti-tilt mechanism to prevent toppling
- Smooth full extension ball bearing runners
- Load carrying capacity of 40kgs



No. of Drawer	Width	Depth	Height
2	465	620	710
3	465	620	1035
4	465	620	1320

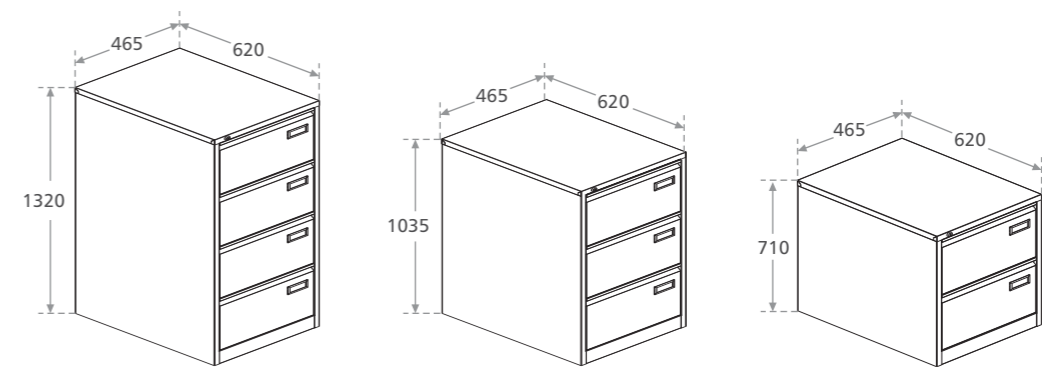

All dimensions in mm





## LOCKERS

Endura + lockers offer a unique concept of starter and add-on modules in order to achieve better space utilisation and ease of installation. Provision for 1 door to 6 door lockers make it ideally suited for IT/ITES companies, manufacturing units, schools, hospitals, gymnasiums etc.

- Provision for hangers for 1 door & 2 door locker unit
- Concealed metal hinges without brackets
- Metal perforations on each door for ventilation
- Provision of pad lock or in-built locking system



6 Compartment Locker



12 Compartment Locker



18 Compartment Locker

Configuration	Width	Depth	Height
1 Door	380	457	1830
2 Door	380	457	1830
4 Door	380	457	1830
6 Door	380	457	1830

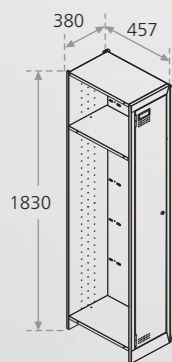

Shelf height = 435 / 1245

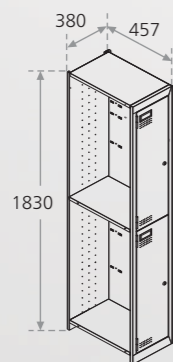

Shelf height = 850

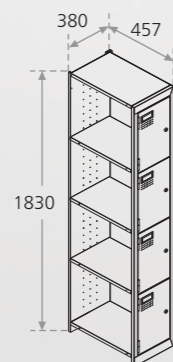

Shelf height = 435



Shelf height = 283



Hanger  
Only Available  
in 1 & 2 Door

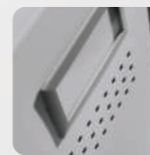

Index Holder  
and Ventilation

All dimensions in mm



Endura + Lockers can be extended by using add-on modules. Any number of units can be added on, limited only by available space.

### Optional accessories



Padlock



Number Lock



Card reading lock



Digital lock

## 2-in-1 CUPBOARDS

Endura+ 2-in-1 cupboards can be used independently by two individuals. Hence the name-2-in-1. These cupboards are suitable for corporates, manufacturing units, PSUs, banks, hostels etc.

- Dual doors with individual locking
- Fitted with premium quality specially designed lock
- Comes with lockable drawers

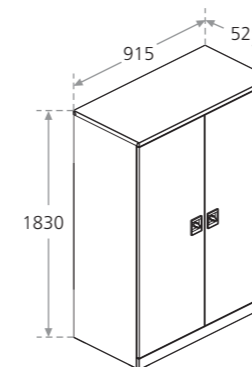

All dimensions in mm



Configuration	Width	Depth	Height
2-in-1 Cupboard	915	525	1830



900 (W) x 350 (D) x 1830 (H)



## SWING DOOR CUPBOARDS

Endura + swing door cupboards are elegant to look at and sturdy in design offering convenient storage solutions with enhanced functionality.

- Flush handle locking with foldable keys
- Concealed hinges without brackets
- Dual purpose shelves for box file / hanging files
- Levelers



Configuration	Width (W)	Depth	Height
2 Levels (Metal)	750 / 900 / 1200	450	715
3 Levels (Metal)	750 / 900 / 1200	450	1200
5 Levels (Metal)	900	450	2015
Book Case (Glass)	900	450	2015



Dual purpose shelves



Adjustable shelves



Flush handle lock

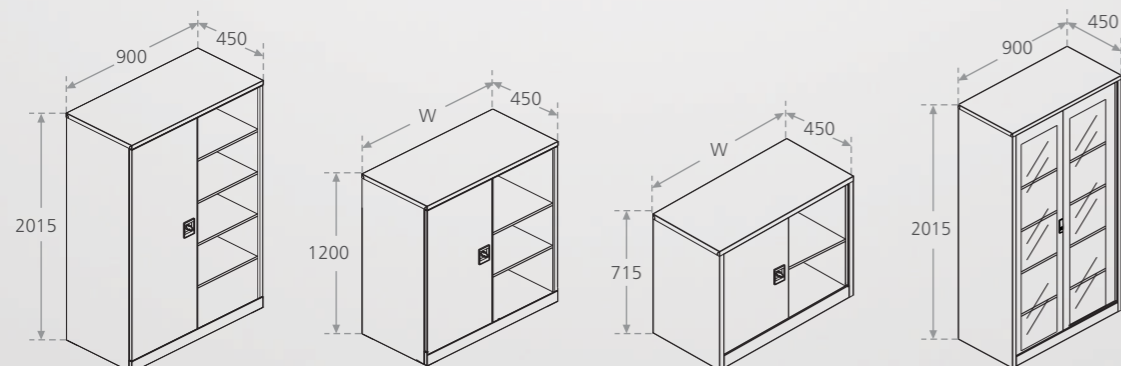

All dimensions in mm



## SLIDING DOOR CUPBOARDS

Sliding door cupboards from Endura + help in providing space saving solutions by increasing aisle space and giving easy access in compact office areas.

- Smooth sliding rails
- Adjustable shelves
- Dual purpose shelves for box file / hanging files
- In-built plastic handle with foldable keys



Dual purpose shelves



Adjustable shelves

Door Configuration	Width (W)	Depth	Height
2 Levels (Metal)	750 / 900 / 1200	450	715
3 Levels (Metal)	750 / 900 / 1200	450	1200
5 Levels (Glass)	900	450	2015

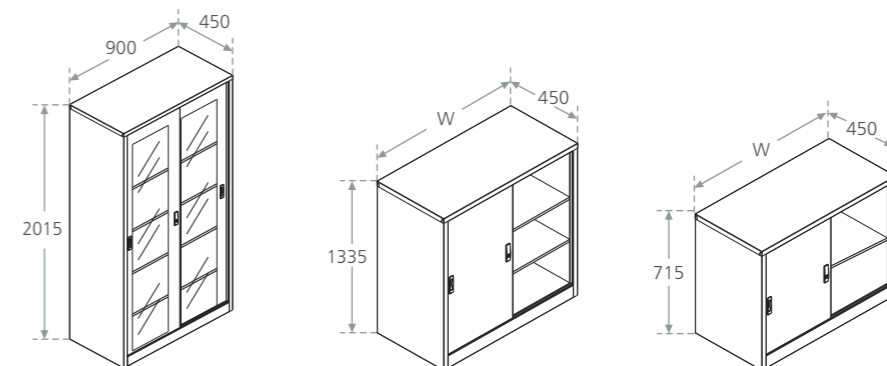

All dimensions in mm



## TAMBOUR DOOR CUPBOARDS

A space saving solution that doesn't compromise on style. Endura+ tambour door cupboards are ideal for on-the-shelf filing requirement as well as under-the-shelf lateral filing.

- Smooth "U" turn factory fitted shutters
- In-built plastic handle with foldable keys
- Adjustable shelves
- Dual purpose shelves for box files / Hanging files



Configuration	Width	Depth	Height
5 Levels	1200	450	2000
3 Levels	1200	450	1000



Dual purpose shelves

Adjustable shelves

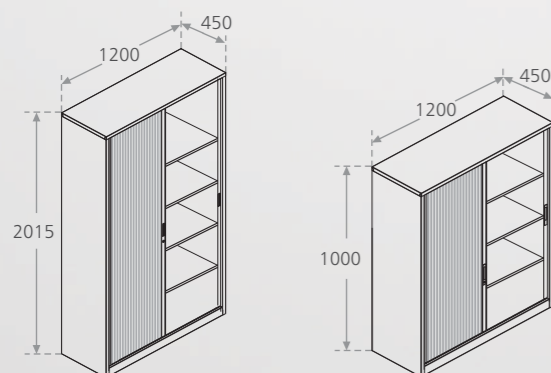

All dimensions in mm

## PEDESTALS

Endura pedestals are strong and rugged - designed to withstand the rigour of busy offices and keep your workplace organized and clutter free.

- Multiple configurations of Box & File type drawers
- Provision of cushion on top for Smart Seating solution
- Drawer fixed on ball bearings
- In-built flush handles for seamless look
- Anti-toppling mechanism for better stability
- Provision for individual and central locking



Configuration	Width	Depth	Height
4 Drawer	400	435	715
2 Drawer + 1 File	400	435	691
3 Drawer	400	435	543
1 Drawer + 1 File	400	435	543
Mobile Caddy	1000	450	610

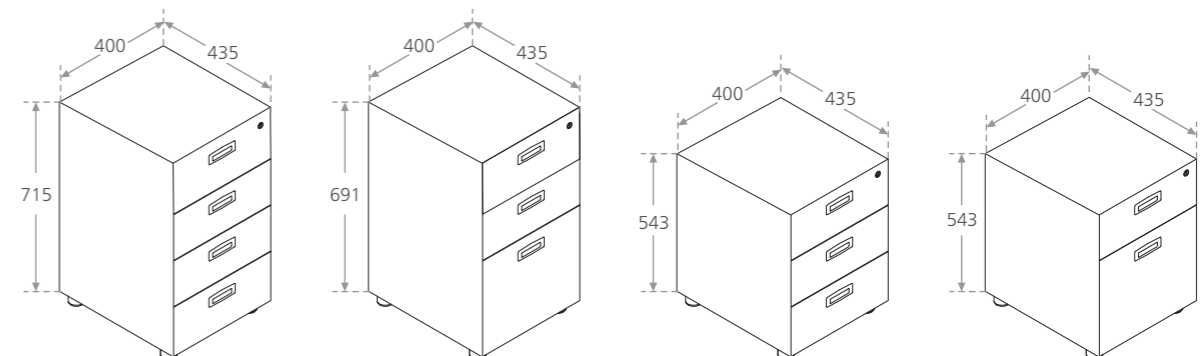

All dimensions in mm

\* Endura Range pedestal comes factory fitted



## TECHNICAL SPECIFICATIONS

Product	CRCA sheet	Pre-Treatment Iron Phosphating	Powder Coat Thickness (60-80 micron)	UDL Per Shelf	Material Thickness
Lateral filing cabinet	✓	✓	✓	40 kg	0.6 mm
Vertical filing cabinet	✓	✓	✓	40 kg	0.8 mm
Lockers	✓	✓	✓	-	0.6 mm
2-in-1 cupboard	✓	✓	✓	40 kg	1.0 mm
Swing door cupboard	✓	✓	✓	40 kg	0.8 mm
Sliding door cupboard	✓	✓	✓	40 kg	0.6 mm
Tambour door cupboard	✓	✓	✓	40 kg	0.6 mm

Pedestals	
Material Thickness	0.8 mm body
Castors	40 mm dia
Cushion (optional)	40 mm PU foam
Prelam Facia (optional)	18 mm thick

Standard Finish  Warm Grey

## Wipro Furniture Advantage

Wipro Furniture provides design solutions that inspire, enhance productivity and creativity through

- A wide range of products for different applications
- Pan India presence - 26 sales offices and dealer network of 50+ dealers
- Designer products from international designers
- Optimised space solutions from a wide variety of modular designs
- Service commitment through designing solutions and developing products to suit customer needs
- Value added economic solutions
- Trustworthiness and reliability of Wipro



Wipro Enterprises Private Limited - **Furniture Business**

Doddakannelli, Sarjapur Road, Bangalore - 560035

Customer care number: 1800 425 1969

Write to us at [vibrant.solutions@wipro.com](mailto:vibrant.solutions@wipro.com)

Ahmedabad: +91 79 40073546, Bangalore: +91 80 40541237, Chandigarh: +91 172 2661355, Chennai: +91 9500088426

Cochin: +91 9387881504, Hyderabad: +91 40 27176082, Indore: +91 731 4023486, Kolkata: +91 33 22829268

Mumbai: +91 7406002777, Nagpur: +91 712 2233562, New Delhi: +91 11 41708122, Pune: +91 20 25535081

Vadodara: +91 8758856507