



International styling desk cum bench solution for classrooms.



[www.wiprofurniturebusiness.com](http://www.wiprofurniturebusiness.com)

xplorer™  
... for the smart ones

- Stationary tray
- Bag hanger
- Book hanger

Amazing convenience



Self grounded leg

Stable structure

More seating comfort

Generous spacing



Rounded off edged tops, slanting edge towards user side

Comfort for long writing hours

Uniformity / Discipline in classroom

Choice of independent or joined units



- Table Top finish : Asian maple
- Choice of seat : Flexible plastic seat / Plymould seat
- Understructure colour : Sparkling silver

Product ordering code; XPLR xx xxxx xxxx

XPLR	XX	XXXX	XXXX
	1S	2200	0001
	2S	2300	0002
			0003
			0004
			0005

1S - 1 Seater ; 2S - 2 Seater

2200 - Flexible plastic seat ; 2300 - Ply mould seat

Flexible plastic seat: 0001 - Red, 2 - Yellow, 3 - Green, 4 - Blue

Ply mould seat: 0005 - Wooden Grain

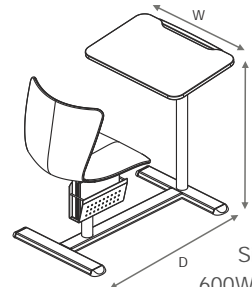

Single Seater  
600W x 862D x 790H

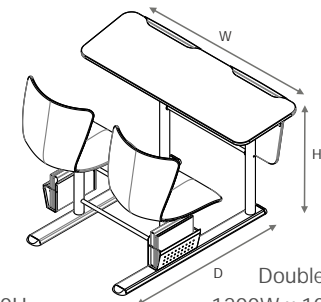

Double Seater  
1200W x 1032D x 790H



Wipro Enterprises Limited - Furniture Business  
No. 134 Doddakannelli, Sarjapur Road, Next to Wipro Corporate Office,  
Bangalore - 560035. Tel: 080-28440011 Fax: 080-28440057  
email: vibrant.solutions@wipro.com

Innovation and Design is a way of life at Wipro.  
We reserve the right to modify the product without prior intimation

Authorised Dealer:

www.wiprofurniturebusiness.com